

**REPLACEMENT PARTS SUITABLE FOR:**
**AUTOGEN RITTER®**

PHB 120®

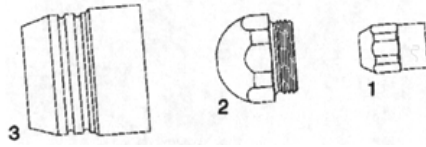

ITEM	CATALOG NUMBER	DESCRIPTION	STD. QTY
1	CS412-02-00	ELECTRODE	10
2	CS412-04-10	TIP 1.0	10
	CS412-04-12	TIP 1.2	10
	CS412-04-14	TIP 1.4	10
	CS412-04-16	TIP 1.6	10
	3	CS413-05-00	NOZZLE CAP W/INBUILT SAFETY

**REPLACEMENT PARTS SUITABLE FOR:**
**BINZEL®**

PSB 60/80/121®

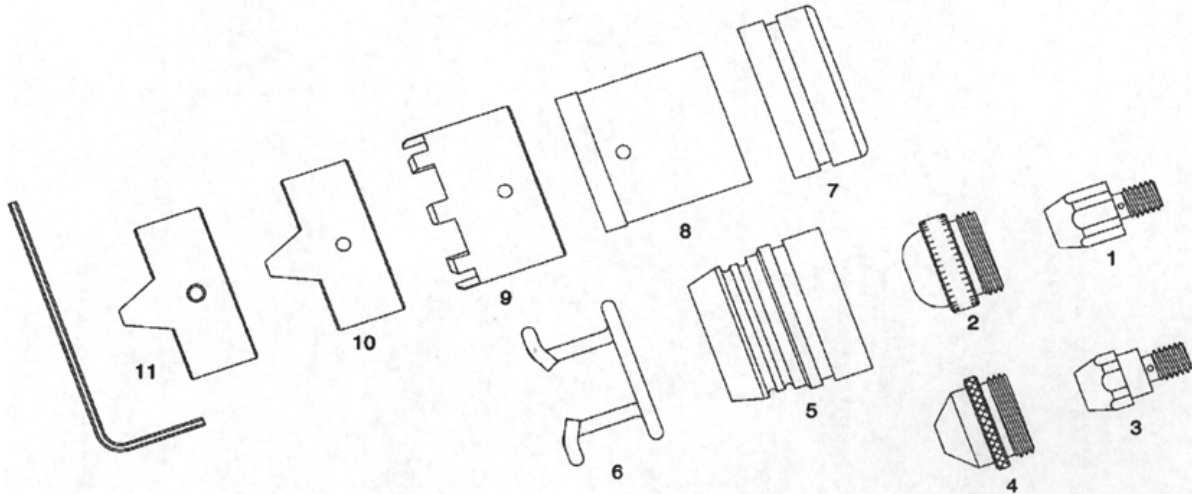

ITEM	CATALOG NUMBER	DESCRIPTION	STD. QTY
1	CS743.0077	ELECTRODE ZR	10
	CS743.0067	ELECTRODE HF	10
2	CS743.0122	TIP 1.0	10
	CS743.0143	TIP 1.3	10
	CS743.0132	TIP 1.5	10
	CS743.0209	TIP 1.8	10
	CS743.0355	TIP 2.0	10
3	CS743.0425	ELECTRODE TAPERED	10
4	CS743.0202	TIP 30° 1.0	10
	CS743.0261	TIP 30° 1.3	10
	CS743.0203	TIP 30° 1.5	10
	CS743.0262	TIP 30° 1.8	10
5	CS743.0131	SPRING SUPPORT	5
6	CS743.0149	SPACER SPRING	10
7	CS743.0125	DISTANCE SLEEVE	5
8	CS743.0126	DISTANCE NOZZLE SUPPORT	5
9	CS743.0127	SPACER NOZZLE CROWN	5
10	CS743.0168	DOUBLE POINTED NOZZLE	5
11	CS743.0267	DOUBLE POINTED NOZZLE W/SCREWS & KEY	5
N/S	CS51856	CIRCLE CUTTING ATTACHMENT	1
N/S	CS51812	CUTTING GUIDE	1

Ergodani is in no way affiliated with AUTOGEN RITTER®, BINZEL®. The parts advertised for sale are not genuine AUTOGEN RITTER®, BINZEL® parts, but are parts made for and by Ergodani. Reference to AUTOGEN RITTER®, BINZEL® machine, torches and numbers are for your convenience only. We reserve the right to substitute genuine AUTOGEN RITTER®, BINZEL® parts in place of Ergodani parts.